

- High reliability
- High dimensional and general effect
- Low noise level in whole operating range
- High volumetric efficiency



Functional Description

The gear Pumps Series GP1-P consists of 2 intermeshing gears (1), one of them connected to the drive shaft. Right or Left hand rotation on the drive shaft generates pressure and flow as given in the technical data section on page 2. The pumps have optimized efficiency through pressurized internal sealing technology (2). The floating bushings (3) with special

bearings (4) are pressure dependent pushed against the gears which guarantee minimum gap clearance between bushing and gears thereby sealing the gears axially. The radial sealing is done by forcing the gears against the body. The gear pumps have 2-Bolt SAE mounting flange (5) and keyed shaft. Pressure and Suction ports are SAE p-Ring Ports.

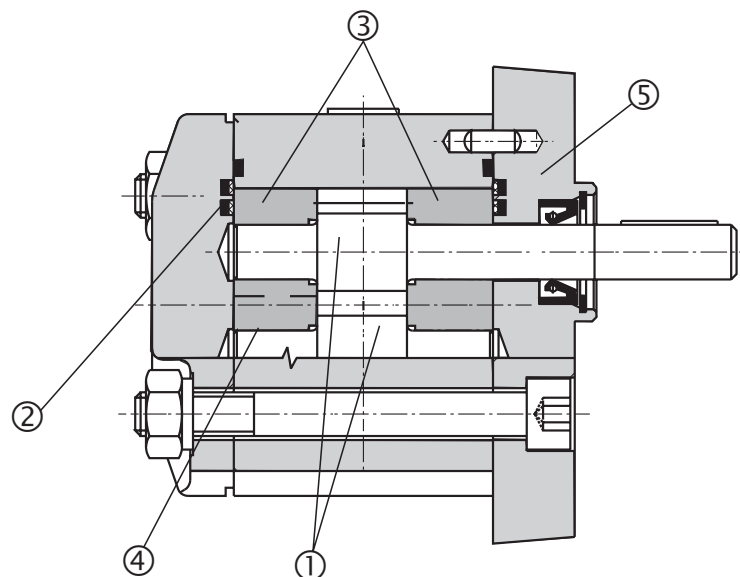
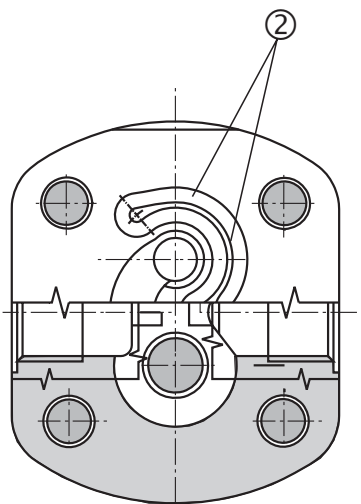

Order Code - Preliminary Technical Information

GP1- P													
Gear pump													
Series													
Nominal displacement													
0.049 cinch/rev (0.8cm ³ /rev)	0.8												
0.073 cinch/rev (1.2cm ³ /rev)	1.2												
0.098 cinch/rev (1.6cm ³ /rev)	1.6												
0.128 cinch/rev (2.1cm ³ /rev)	2.1												
0.153 cinch/rev (2.5cm ³ /rev)	2.5												
0.201 cinch/rev (3.3cm ³ /rev)	3.3												
0.220 cinch/rev (3.6cm ³ /rev)	3.6												
0.269 cinch/rev (4.4cm ³ /rev)	4.4												
0.293 cinch/rev (4.8cm ³ /rev)	4.8												
0.354 cinch/rev (5.8cm ³ /rev)	5.8												
0.378 cinch/rev (6.2cm ³ /rev)	6.2												
0.482 cinch/rev (7.9cm ³ /rev)	7.9												
Sense of rotation:													
clockwise	R												
counterclockwise	L												
Seals													
no designation (Other upon request)													
Flange													
S SAE AA (SAE J744C)													
Pressure Ports													
O O-ring Ports to SAE J1926 (ISO 11926)													
Suction Ports													
I O-ring Ports to SAE J1926 (ISO 11926)													
K3 Cylindrical Keyed Shaft 3/8													

Technical Data

NOMINAL SERIES SPECIFICATIONS		P-0.8	P-1.2	P-1.6	P-2.1	P-2.5	P-3.3	P-3.6	P-4.4	P-4.8	P-5.8	P-6.2	P-7.9
Nominal displacement	C.I.R	0.049	0.073	0.098	0.128	0.153	0.201	0.220	0.269	0.293	0.354	0.378	0.482
Speed - nominal		1750	1750	1750	1750	1750	1750	1750	1750	1750	1750	1750	1750
maximum	RPM	5000	5000	5000	4500	4500	4000	4000	4000	3800	3800	3500	3000
minimum		800	600	600	600	600	600	500	500	500	500	500	500
Pressure on the inlet - nominal	PSI	+7.25											
maximum		-4.35											
minimum		-4.35											
Pressure on the outlet - max	PSI	4058	4058	4058	4058	4058	4058	3769	3624	3334	2899	2609	2319
continuous		4348	4348	4348	4348	4348	4348	4058	3914	3624	3189	2899	2609
maximum		4348	4348	4348	4348	4348	4348	4058	3914	3624	3189	2899	2609
Nominal outlet flow (min.)*	GPM	0.335	0.505	0.674	0.882	1.051	1.387	1.516	1.849	2.021	2.441	2.615	3.329
Max. flow **	GPM	1.000	1.426	1.902	2.247	2.675	3.225	3.508	4.089	4.337	5.240	5.160	5.635
Power demand-nominal	HP	1.073	1.609	2.012	2.682	3.218	4.291	4.425	5.095	5.095	5.364	5.230	5.900
(max.)*		1.073	1.609	2.012	2.682	3.218	4.291	4.425	5.095	5.095	5.364	5.230	5.900
Max. Power demand **	HP	3.20	4.80	6.40	7.56	9.00	10.56	10.75	12.53	12.16	12.93	11.58	11.40
Efficiency - hydraulic		min. 0.9											
total		min. 0.8											
Pressure fluid		Petroleum oils HM, HV, according CETOP RP 91 H Viscosity classes SO VG 32, 46 and 68											
Fluid temperature range	°F	-4 to +176											
(operating)		-4 to +176											
Operating viscosity range	SUS	98 to 490 (continuous), 5880 (max.), 49 (min.)											
Maximum degree of fluid		Class22/19/16 (p2 < 2901 PSI), class 20/17/14 (p2 > 2901 PSI) according to											
contamination		ISO 4406 (1999)											
Ambient temperature range	°F	-4 to +131											
Mass	lb (kg)	1.80 (0.82)	1.85 (0.84)	1.87 (0.85)	1.91 (0.87)	1.96 (0.89)	2.03 (0.92)	2.05 (0.93)	2.12 (0.96)	2.16 (0.98)	2.25 (1.02)	2.29 (1.04)	2.43 (1.10)
Mountin position		any											

* for nominal speed and maximum continuous pressure ** for maximum speed and maximum pressure

Performance Data

measured at $v = 166 \text{ SUS (} 35 \text{ mm}^2 \cdot \text{s}^{-1}\text{)}$ and $t = 122^\circ\text{F (} 50^\circ\text{C)}$

Outlet flow in relation to power demand and outlet pressure

Nominal Size 0,8

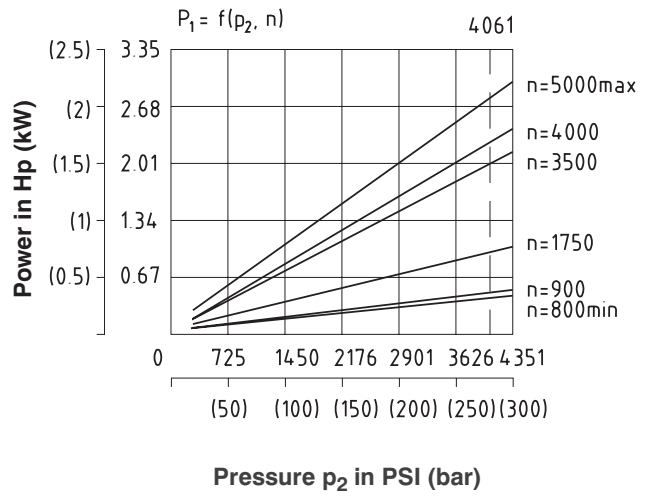
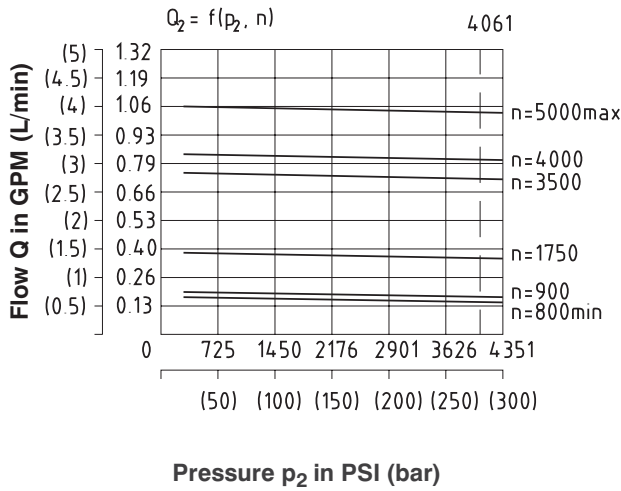

Nominal Size 1,2

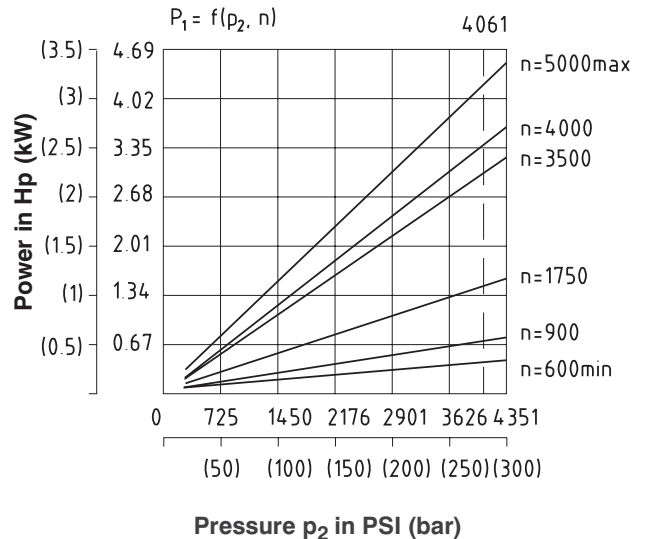
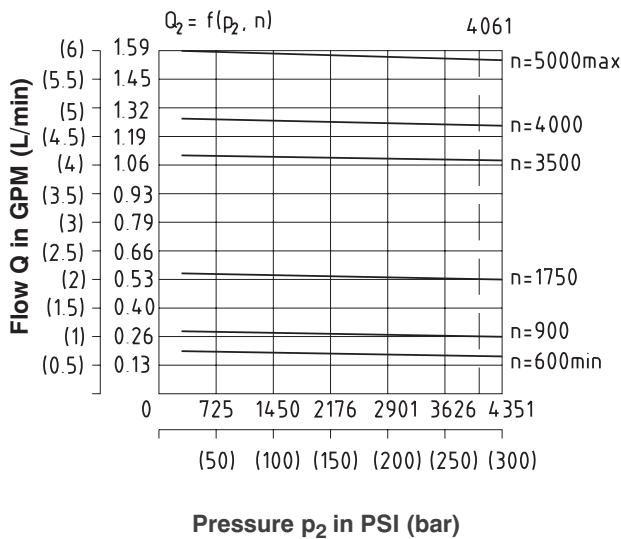

Nominal Size 1,6

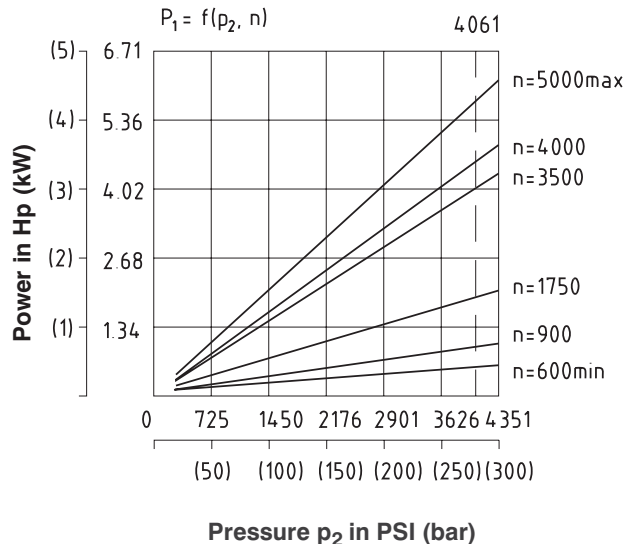
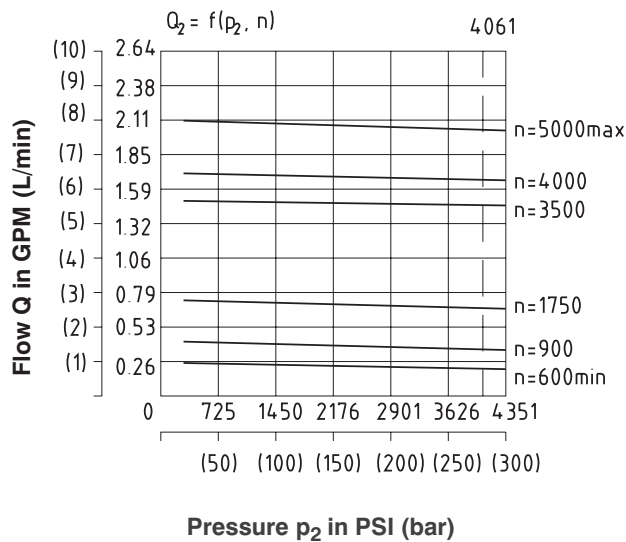

Performance Data

measured at $v = 166 \text{ SUS } (35 \text{ mm}^2 \cdot \text{s}^{-1})$ and $t = 122^\circ\text{F } (50^\circ\text{C})$

Nominal Size 2,1

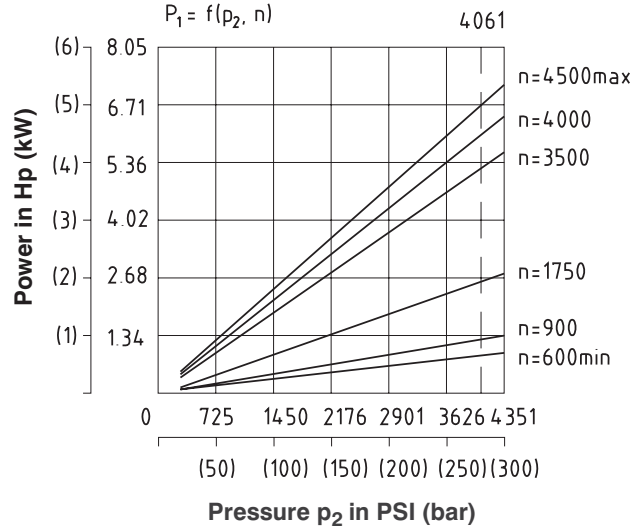
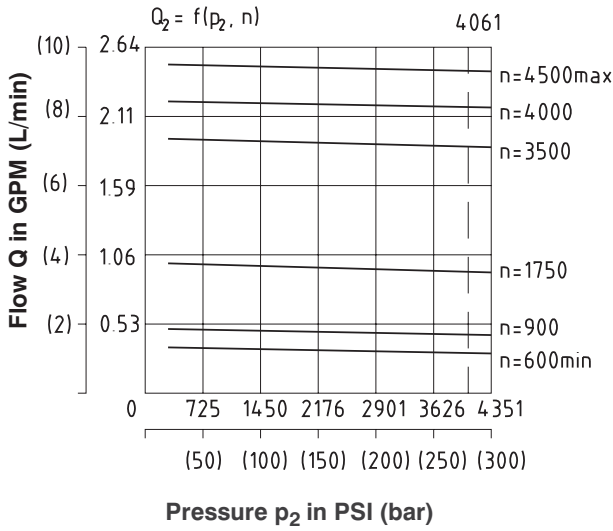

Nominal Size 2,5

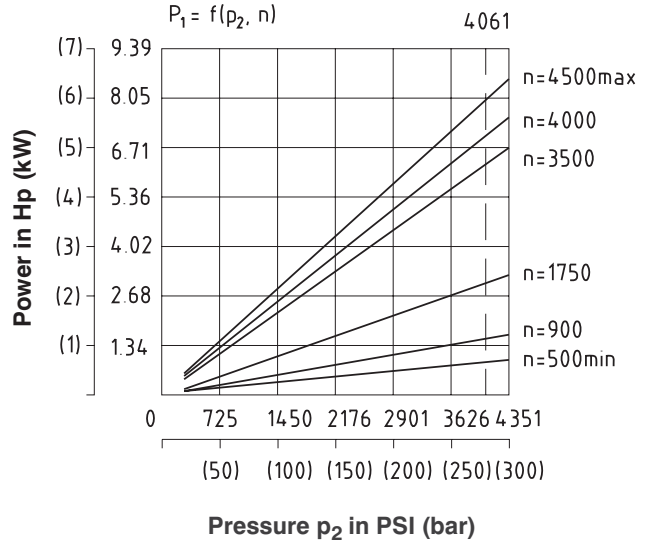
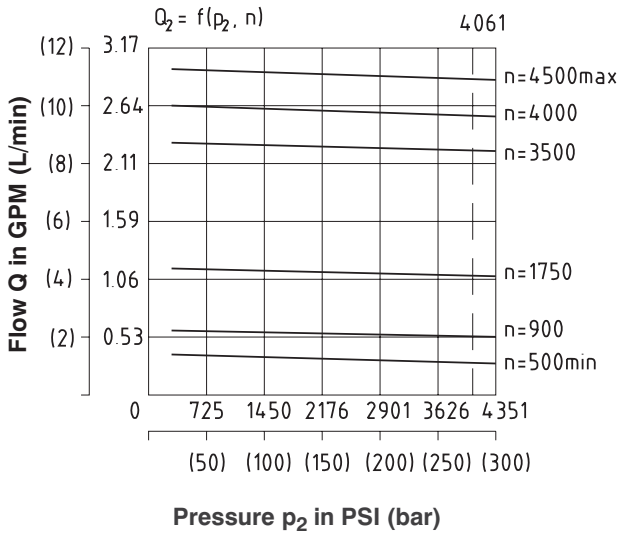

Nominal Size 3,3

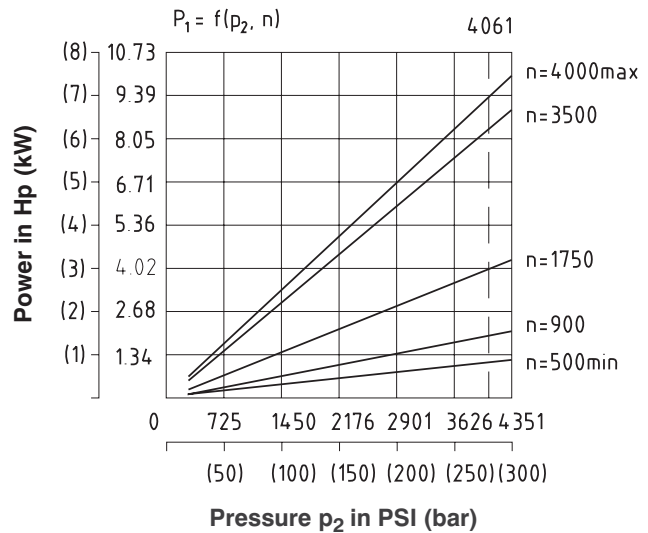
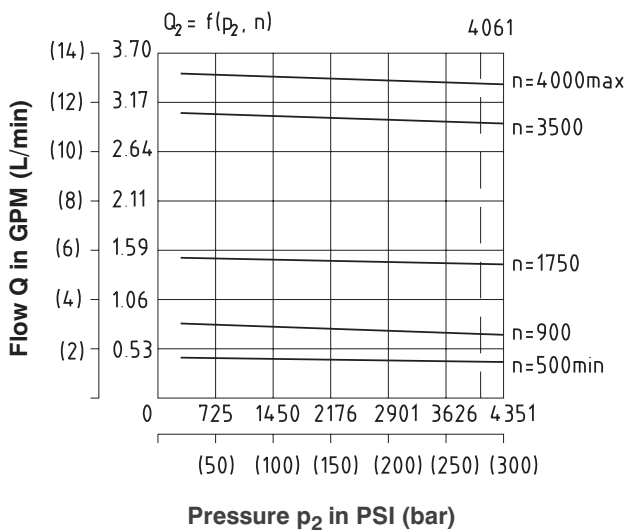

Performance Data

measured at $v = 166 \text{ SUS } (35 \text{ mm}^2 \cdot \text{s}^{-1})$ and $t = 122^\circ\text{F } (50^\circ\text{C})$

Nominal Size 3,6

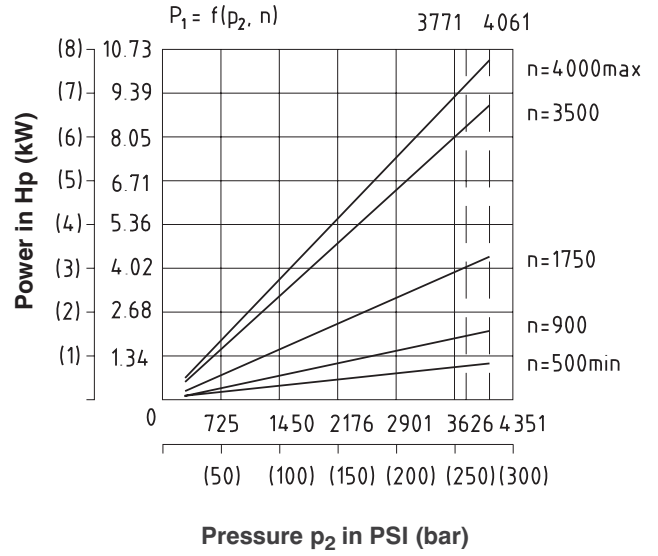
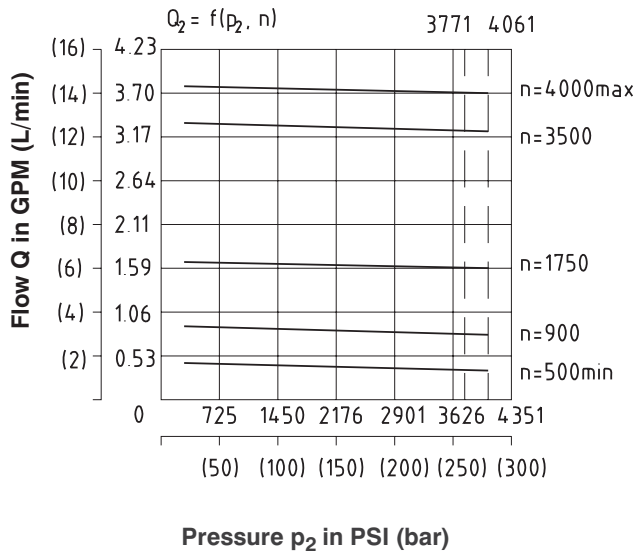

Nominal Size 4,4

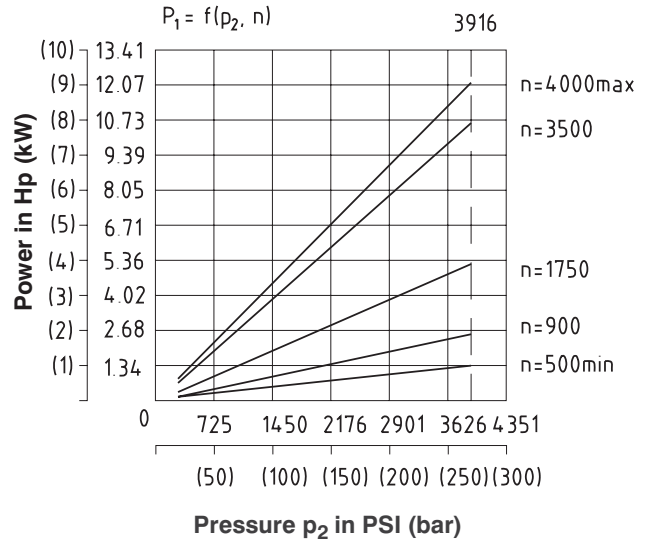
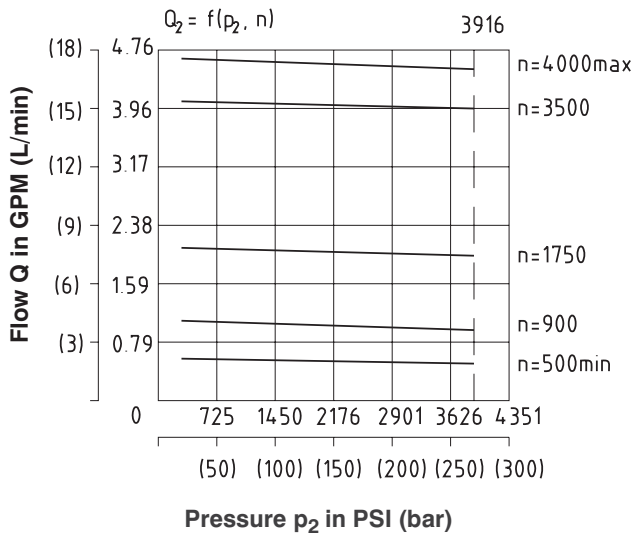

Nominal Size 4,8

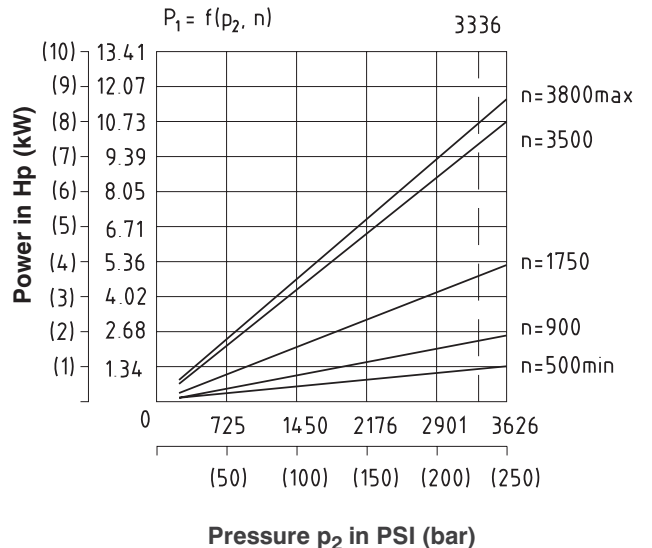
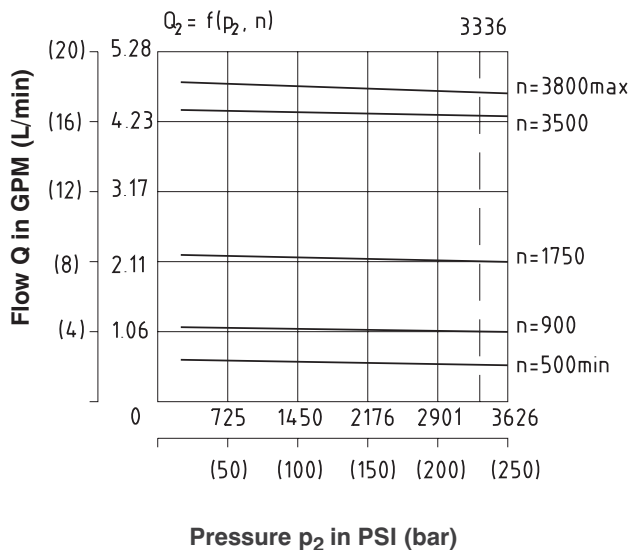

Performance Data

measured at $v = 166 \text{ SUS } (35 \text{ mm}^2 \cdot \text{s}^{-1})$ and $t = 122^\circ\text{F } (50^\circ\text{C})$

Nominal Size 5,8

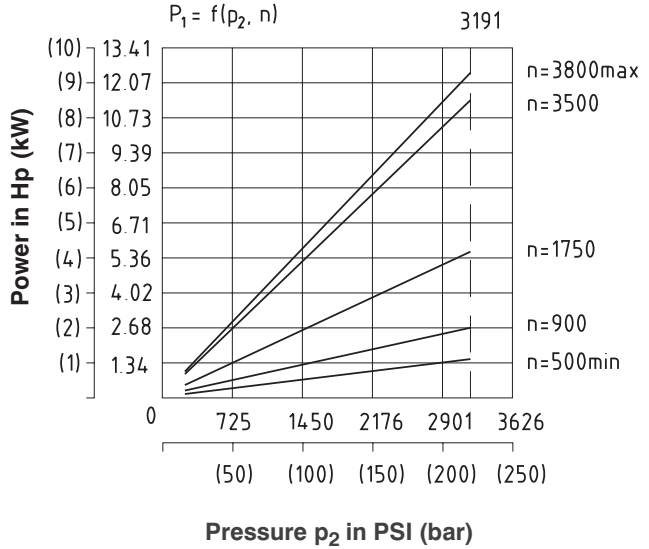
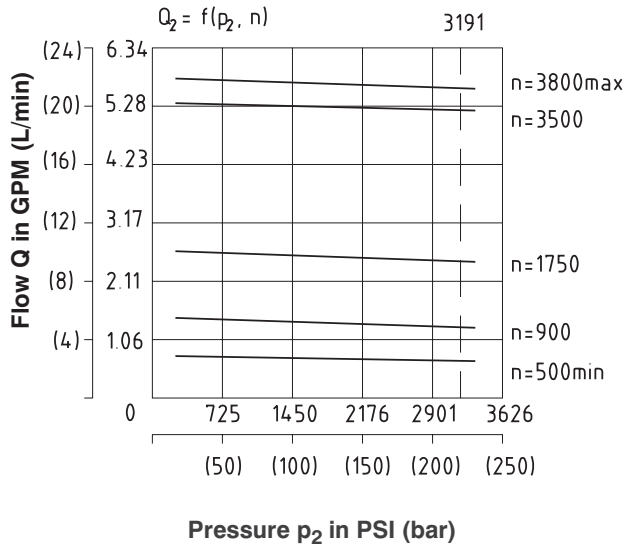

Nominal Size 6,2

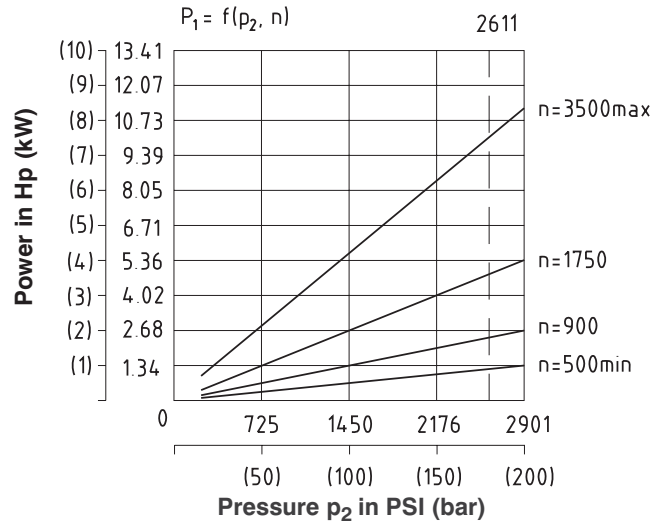
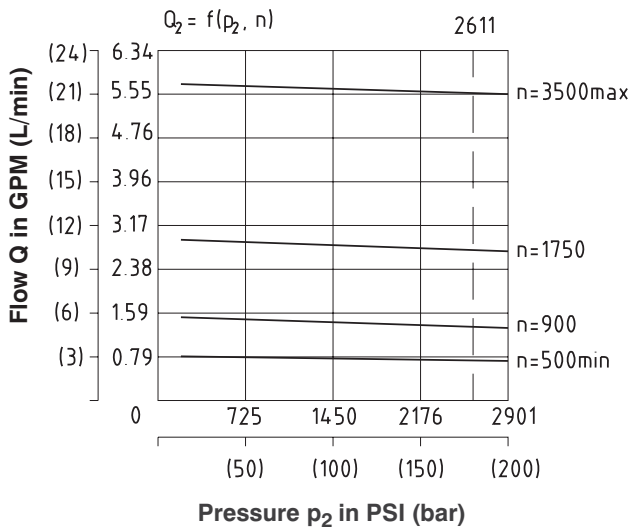

Nominal Size 7,9

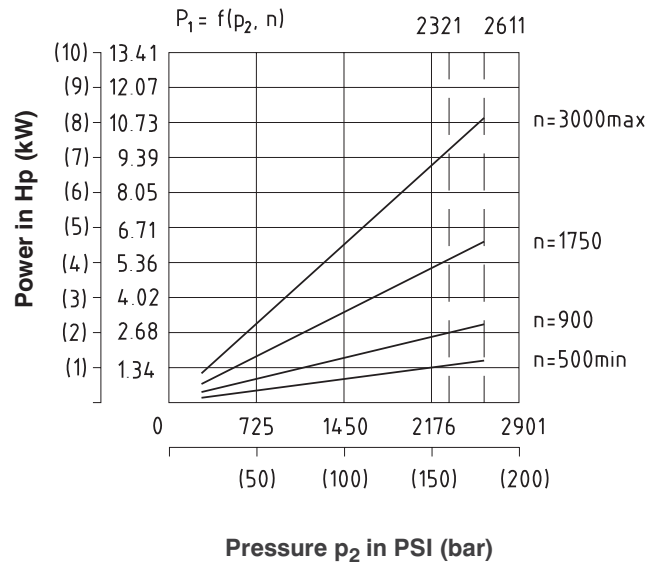
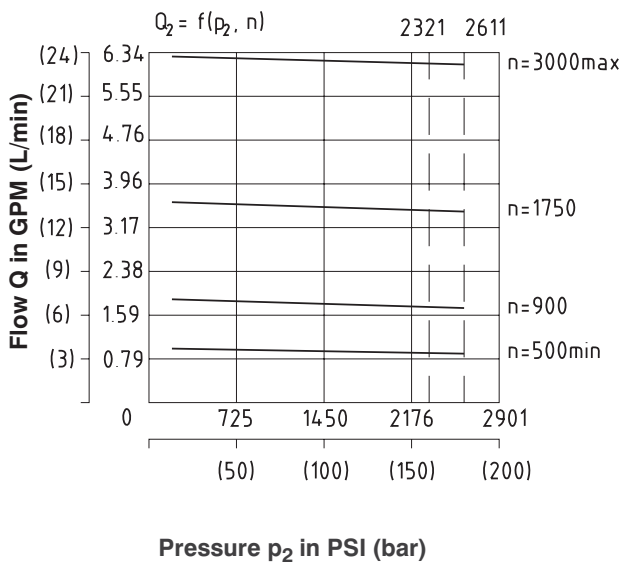

Pressure rating on the P - series gear pumps in relationship to revolutions

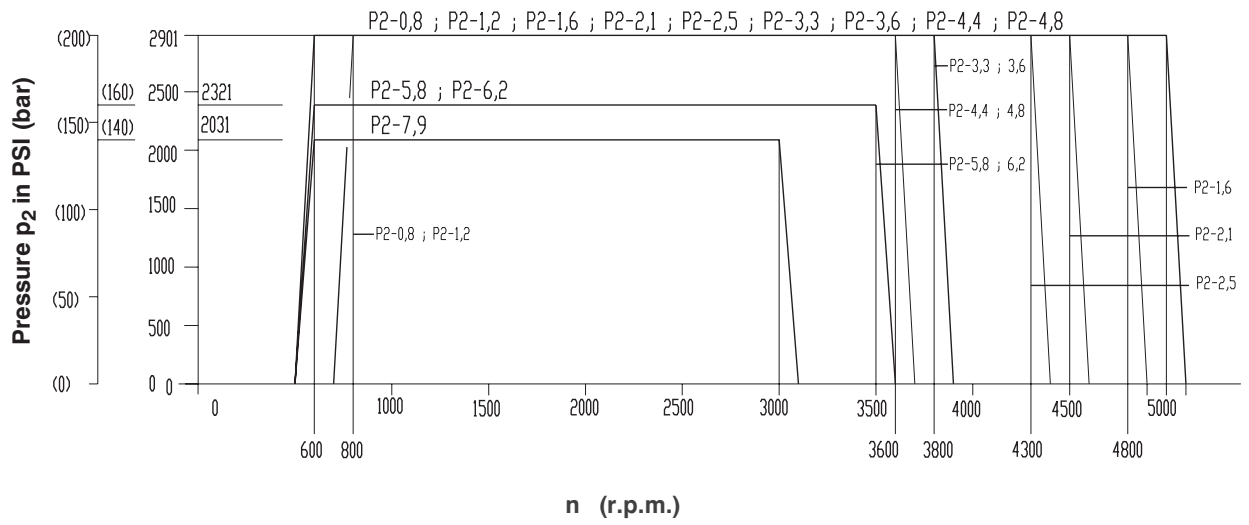

Pump Dimensions

Dimensions in inches

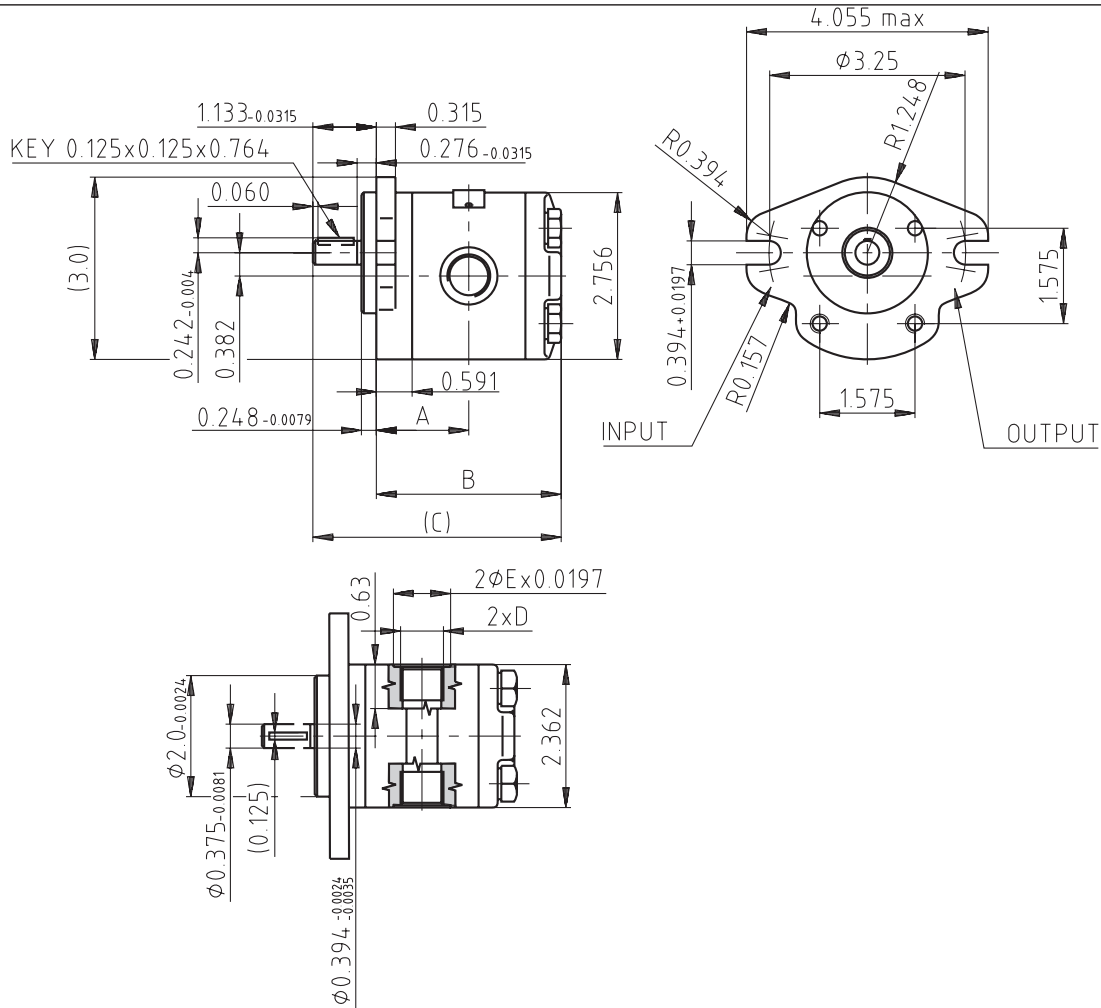

Note: The right hand rotation pump is drawn, the inlet and outlet ports of the left hand rotation pump are interchanged.

Table of Dimensions

CODE	Displacement in ³ /1 (cm ³ /1)	Nom. Press. PSI (bar)	Dimension (")				
			A	B	C	D	E
P - 7.9	0.482 (7,9)	2319 (160)	1.764	3.583	4.677	7/8 -14 UNF- 2B	1.346
P - 6.2	0.378 (6,2)	2609 (180)	1.638	3.327	4.421	7/8 -14 UNF- 2B	1.346
P - 5.8	0.354 (5,8)	2899 (200)	1.610	3.268	4.362	7/8 -14 UNF- 2B	1.346
P - 4.8	0.293 (4,8)	3334 (230)	1.535	3.110	4.205	7/8 -14 UNF- 2B	1.346
P - 4.4	0.269 (20,0)	3624 (250)	1.504	3.051	4.146	7/8 -14 UNF- 2B	1.346
P - 3.6	0.220 (3,6)	3769 (260)	1.449	2.933	4.027	7/8 -14 UNF- 2B	1.346
P - 3.3	0.201 (3,3)	4058 (280)	1.425	2.894	3.988	7/8 -14 UNF- 2B	1.346
P - 2.5	0.153 (2,5)	4058 (280)	1.366	2.775	3.870	3/4 -16 UNF- 2B	1.189
P - 2.1	0.128 (2,1)	4058 (280)	1.335	2.716	3.811	3/4 -16 UNF- 2B	1.189
P - 1.6	0.098 (1,6)	4058 (280)	1.303	2.657	3.752	3/4 -16 UNF- 2B	1.189
P - 1.2	0.073 (1,2)	4058 (280)	1.275	2.598	3.693	3/4 -16 UNF- 2B	1.189
P - 0.8	0.049 (0,8)	4058 (280)	1.244	2.539	3.634	3/4 -16 UNF- 2B	1.189

Caution!

- The packing foil is recyclable.
- Certified documentation is available per request.

ARGO-HYTOS a. s. CZ - 543 15 Vrchlábí
 Tel.: +420-499-403111, Fax: +420-499-403421
 E-mail: sales.cz@argo-hytos.com
 www.argo-hytos.com