

- High reliability
- High dimensional and general effect
- Low noise level in whole operating range
- High volumetric efficiency



Functional Description

The gear Pumps Series GP1-Q consists of 2 intermeshing gears (1), one of them connected to the drive shaft. Right or Left hand rotation on the drive shaft generates pressure and flow as given in the technical data section on page 2. The pumps have optimized efficiency through pressurized internal sealing technology (2). The floating bushings (3) with special bearings (4) are pressure dependent pushed against

the gears which guarantee minimum gap clearance between bushing and gears thereby sealing the gears axially. The radial sealing is done by forcing the gears against the body. The gear pumps have 2-Bolt SAE mounting flange (5) and keyed shaft. Pressure port is SAE O-Ring Port and Suction ports are SAE - Flange Ports.

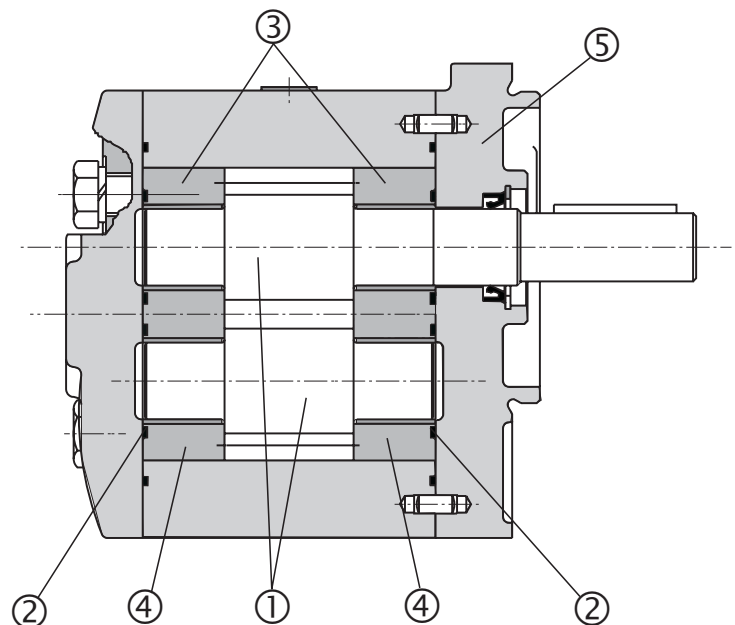
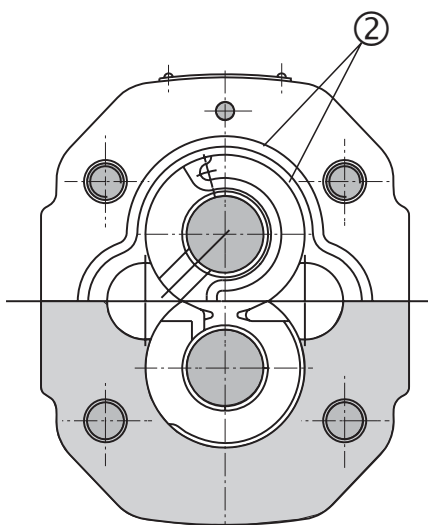

Order Code

GP1- Q

Gear pump

Series

Nominal displacement

0.610 cinch/rev (10cm ³ /rev)	10
1.037 cinch/rev (17cm ³ /rev)	17
1.648 cinch/rev (27cm ³ /rev)	27
2.075 cinch/rev (34cm ³ /rev)	34
2.624 cinch/rev (43cm ³ /rev)	43
3.112 cinch/rev (51cm ³ /rev)	51
3.723 cinch/rev (61cm ³ /rev)	61
4.333 cinch/rev (71cm ³ /rev)	71
5.004 cinch/rev (82cm ³ /rev)	82
6.102 cinch/rev (100cm ³ /rev)	100

Direction of rotation:

Clockwise **R**
Counterclockwise **L**

Seals
NBR
no designation
(Other upon request)

Flange
SAE B (SAE J744C)
B

Pressure Ports
O-ring Ports to SAE J1926 (ISO 11926)
O

Suction Ports
Flange face to SAE J518
F

K7 Cylindrical Keyed Shaft 7/8

Technical Data

Nominal series specifications		Q 10	Q 17	Q 27	Q 34	Q 43	Q 51	Q 61	Q 71	Q 82	Q 100	
Nominal displacement	cinch	0.610	1.037	1.648	2.075	2.624	3.112	3.723	4.333	5.004	6.102	
Speed - nominal	RPM	1750	1750	1750	1750	1750	1750	1750	1750	1750	1750	
		maximum	3000	3000	3000	2800	2500	2500	2000	1800	1800	1800
		minimum	600	600	600	600	600	500	500	500	500	500
Pressure on the inlet -nominal	PSI	+7.25 - 4.35										
maximum												
Pressure on the outlet	PSI	3916 4206 4206 4061 3916 3624 3334 3044 2611 2611 4206 4496 4496 351 4206 3916 3624 3334 2901 2901										
max.continuous												
maximum												
Nominal outlet flow (min.)*	GPM	4.200	7.133	11.359	14.318	18.096	21.477	25.676	29.904	34.607	42.135	
Max. flow **	GPM	7.133	12.152	19.020	22.719	25.625	30.380	28.795	30.380	34.870	42.796	
Power demand-nominal(max.)*	HP	12.605	23.066	36.476	44.254	54.043	59.00	65.308	69.063	69.063	83.814	
Max. Power demand **	HP	19.713	41.572	65.710	75.097	81.132	87.166	77.109	73.756	77.779	95.212	
Efficiency - hydraulic total		min. 0.9 min. 0.8										
Pressure fluid		Petroleum oils HM, HV, according CETOP RP 91 H Viscosity classes SO VG 32, 46 and 68										
Fluid temperature range (operating)	°F	+5 to +158										
Operating viscosity range	SUS	98 to 1840										
Maximum degree of fluid contamination		Class 21/18/15 according to ISO 4406 (1999)										
Ambient temperature range	°F	-4 to +131										
Mass	lb	17.09	19.84	20.28	20.94	21.83	22.60	23.24	24.45	25.09	25.73	
	(kg)	(7.75)	(9.00)	(9.20)	(9.50)	(9.90)	(10.25)	(10.54)	(11.09)	(11.38)	(11.67)	
Mounting position		any										

* at nominal speed and maximum continuous pressure ** at maximum speed and maximum pressure

Performance Data

measured at $v = 166 \text{ SUS (} 35 \text{ mm}^2 \cdot \text{s}^{-1}\text{)}$ and $t = 122^\circ\text{F (} 50^\circ\text{C)}$

Outlet flow in relation to power demand and outlet pressure

Nominal Size 10

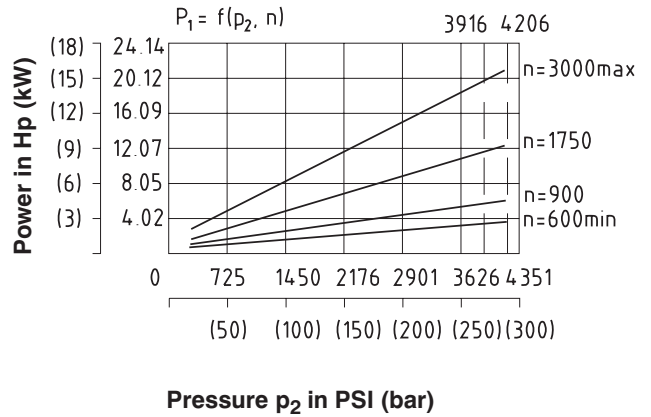
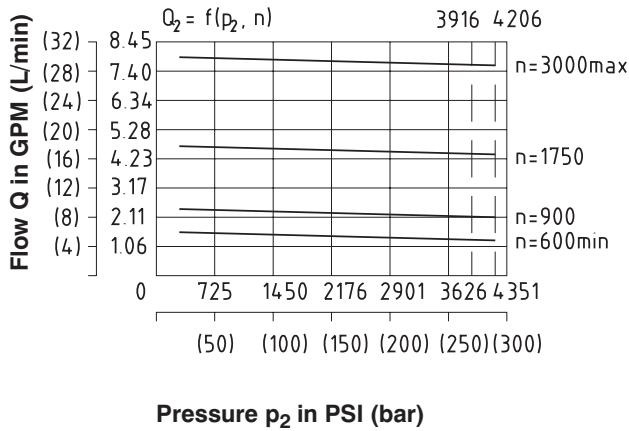

Nominal Size 17

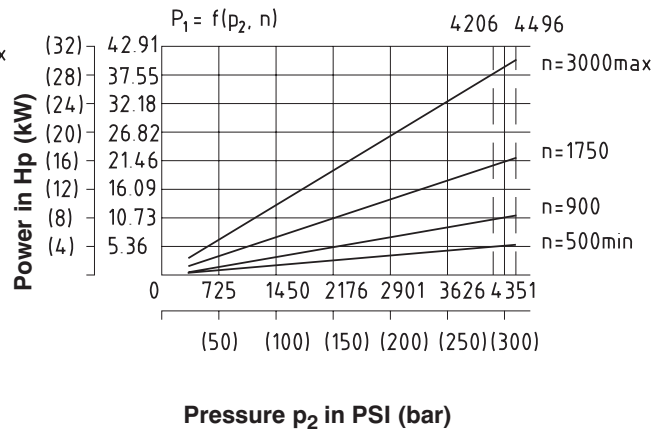
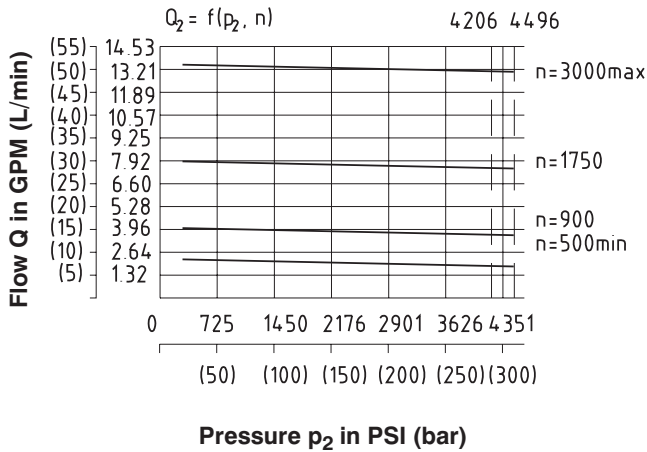

Nominal Size 27

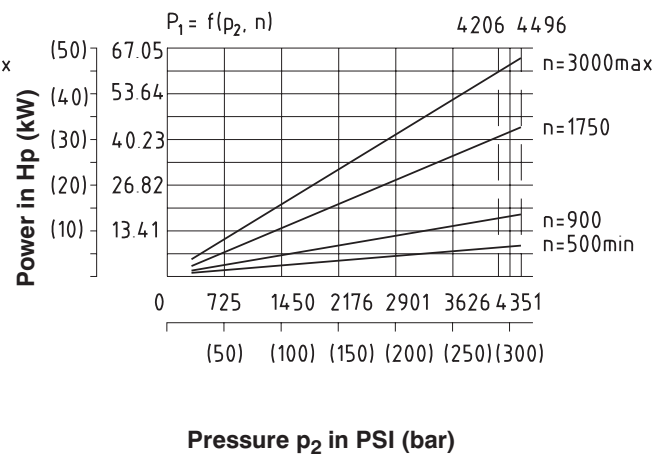
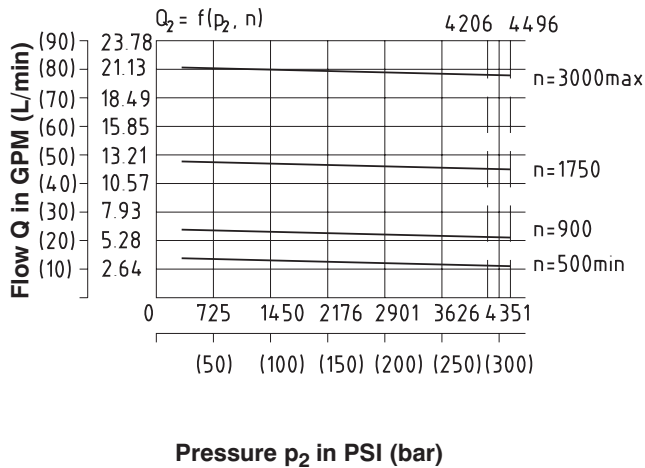

Performance Data

measured at $v = 166 \text{ SUS } (35 \text{ mm}^2 \cdot \text{s}^{-1})$ and $t = 122^\circ\text{F } (50^\circ\text{C})$

Nominal Size 34

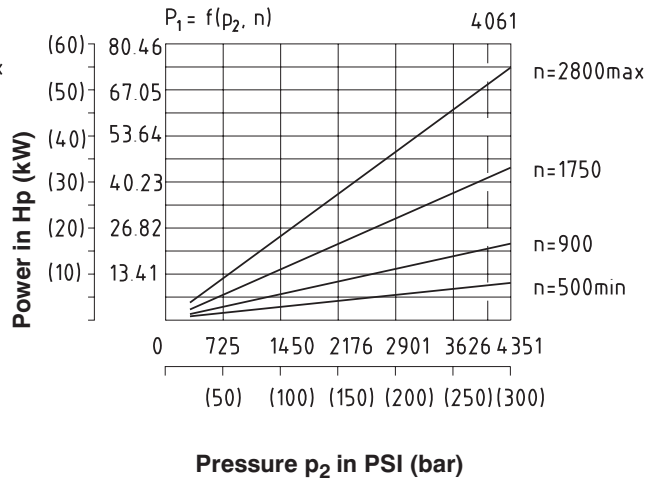
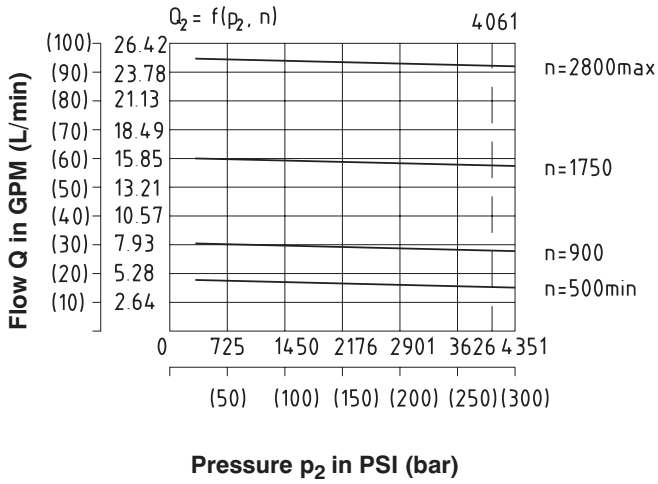

Nominal Size 43

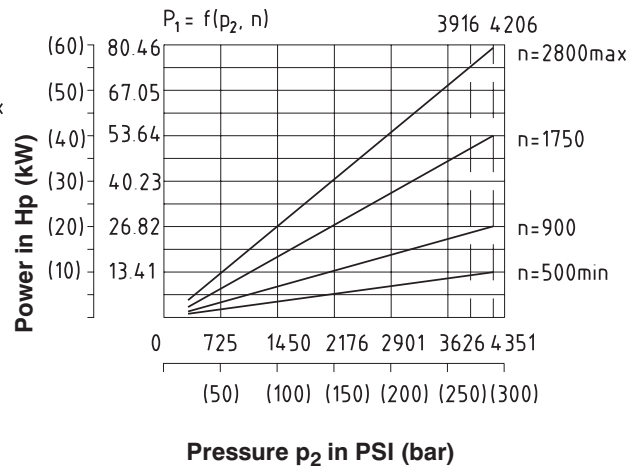
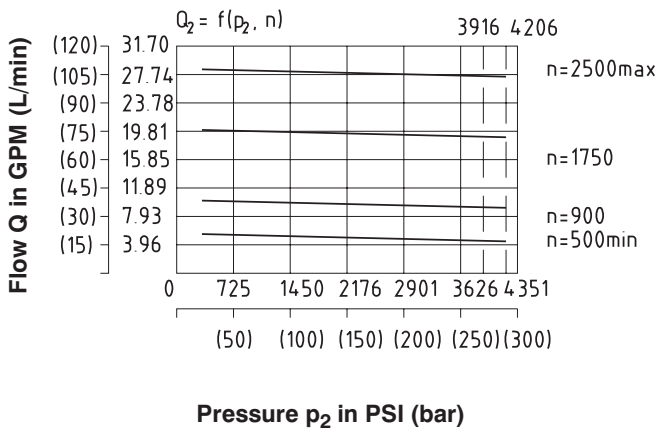

Nominal Size 51

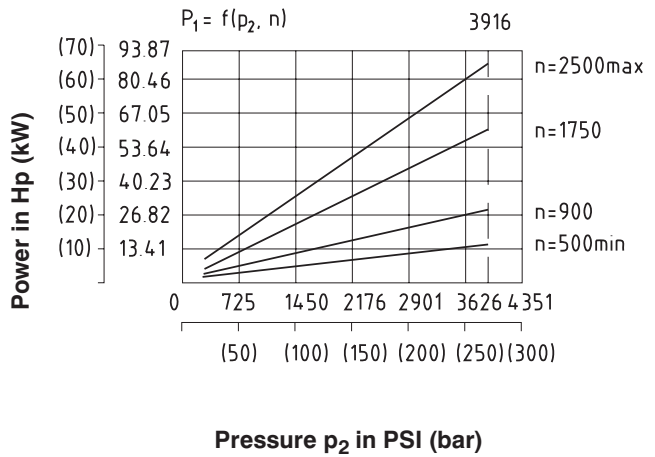
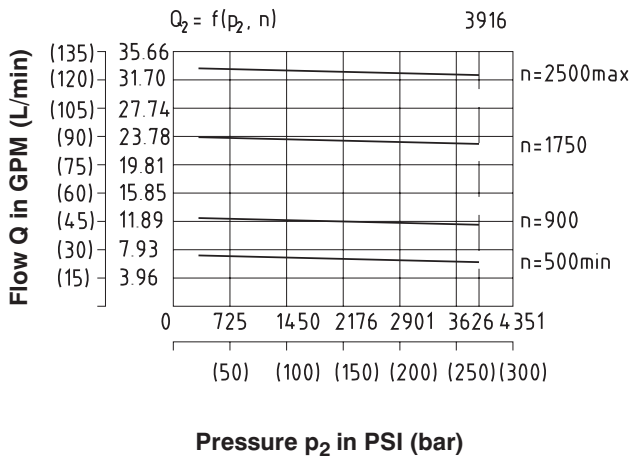

Performance Data

measured at $v = 166 \text{ SUS (} 35 \text{ mm}^2 \cdot \text{s}^{-1}\text{)}$ and $t = 122^\circ\text{F (} 50^\circ\text{C)}$

Nominal Size 61

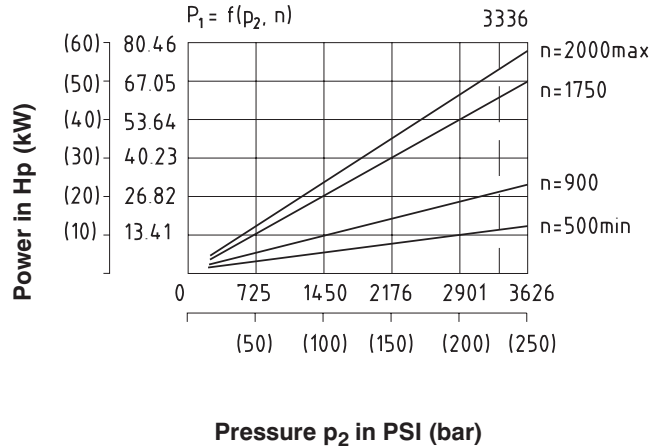
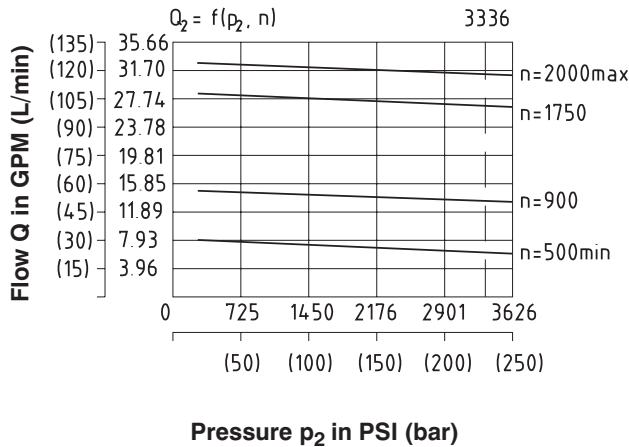

Nominal Size 71

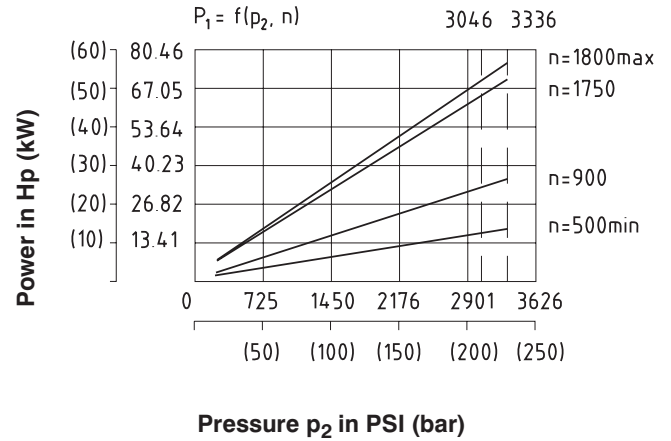
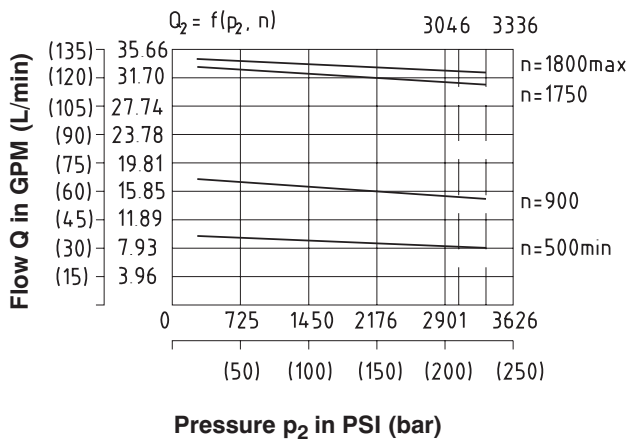

Nominal Size 82

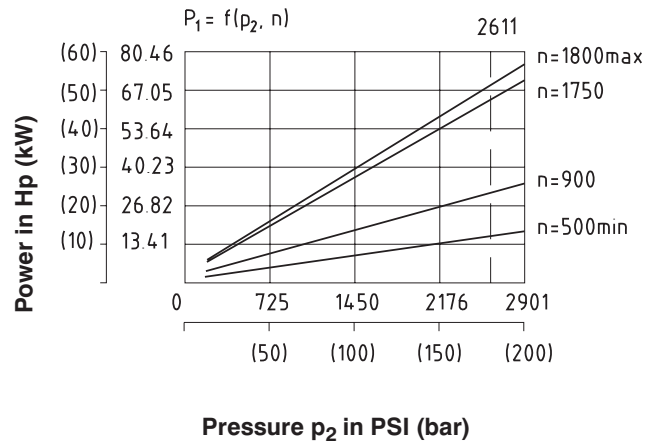
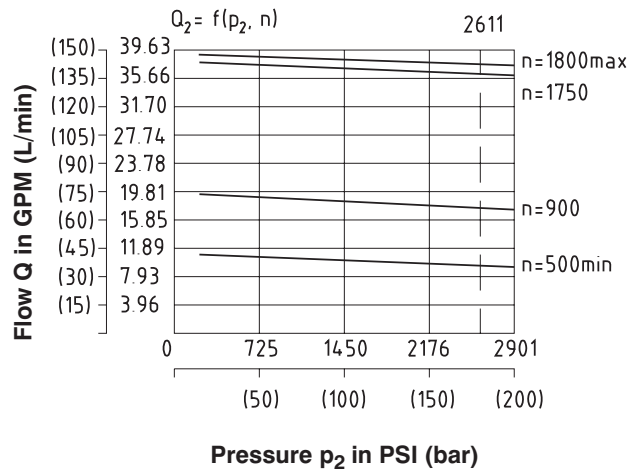

Performance Data

measured at $v = 166 \text{ SUS } (35 \text{ mm}^2 \cdot \text{s}^{-1})$ and $t = 122^\circ\text{F } (50^\circ\text{C})$

Nominal Size 100

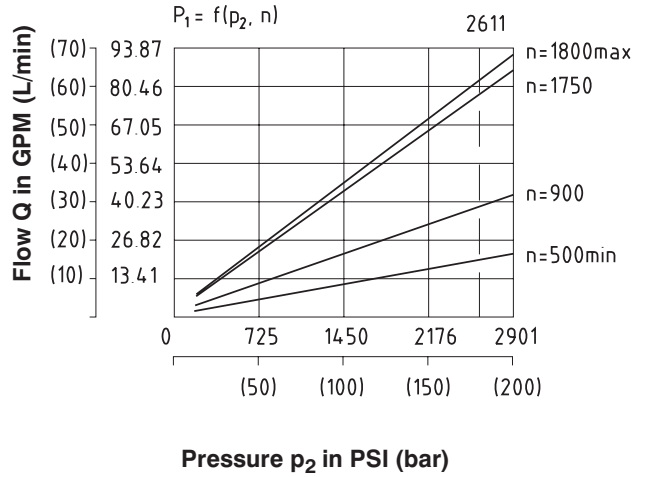
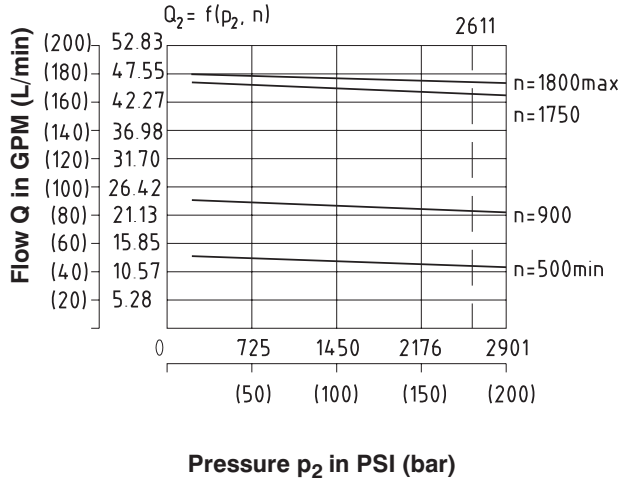

Pressure rating on the Q - series gear pumps in relationship to revolutions

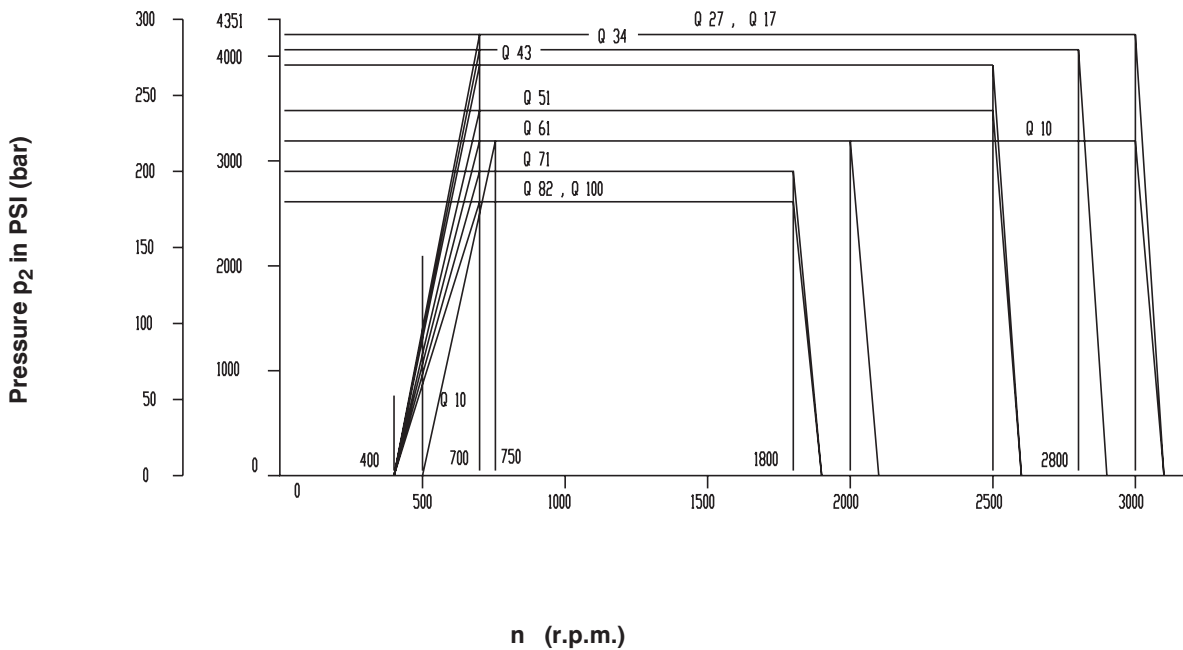

Pump Dimenions

Dimensions in inches

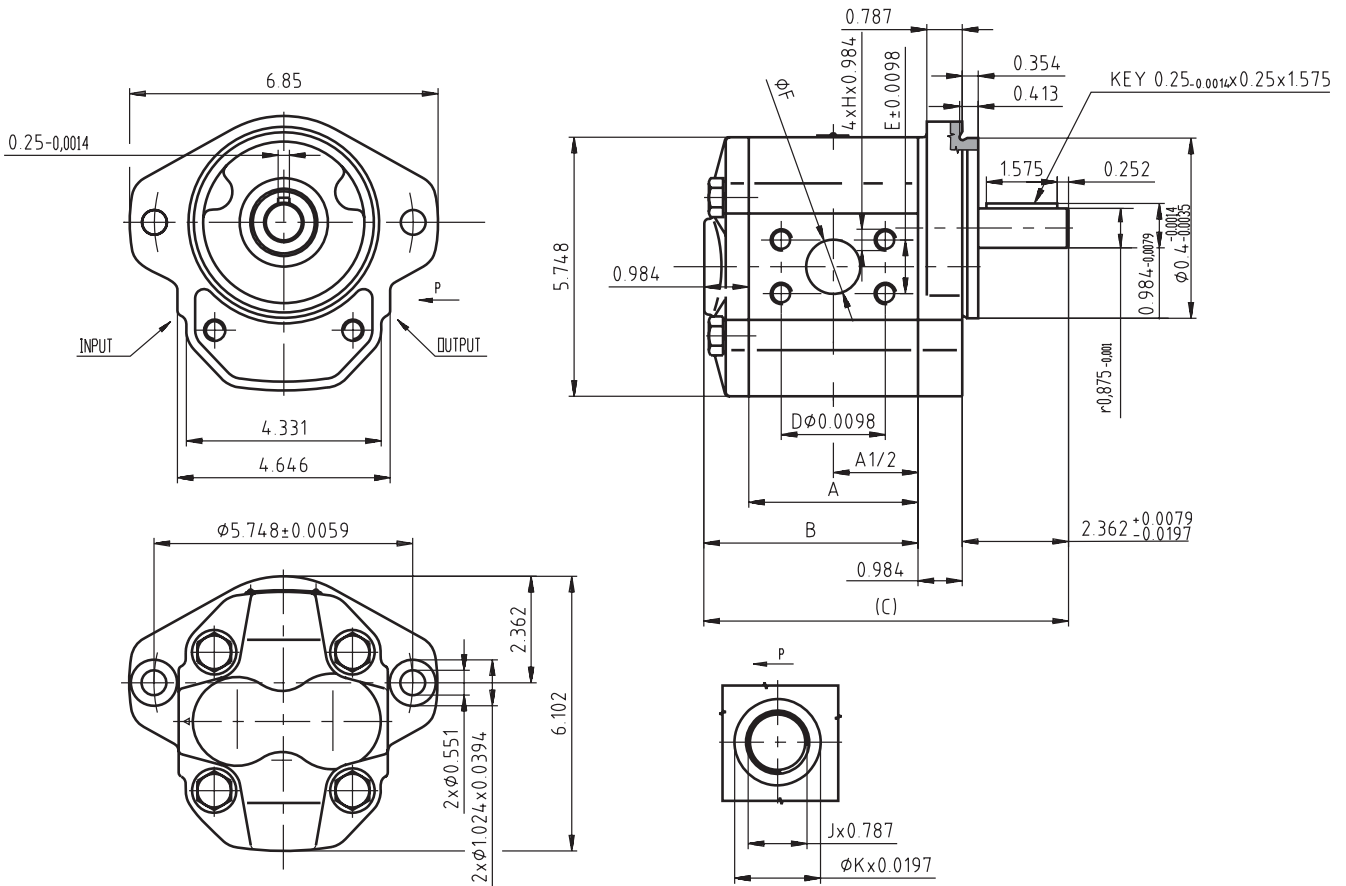

Note: The right hand rotation pump is drawn, the inlet and outlet ports of left hand rotation pump are interchanged.

Table of dimensions

CODE	Displ. in ³ /1 (cm ³ /1)	Nominal Pressure PSI (bar)	Dimension (")								
			A	B	C	D	E	F	H	J	K
Q - 10	0.610 (10.0)	3916 (270)	2.441	3.425	6.772	1.031	2.063	1.000	M10x1.5	1-1/16-12UN-2B	1.622
Q - 17	1.037 (17.0)	4206 (290)	2.677	3.661	7.008	1.031	2.063	1.000	M10x1.5	1-1/16-12UN-2B	1.622
Q - 27	1.648 (27.0)	4206 (290)	3.012	3.997	7.343	1.031	2.063	1.000	M10x1.5	1-1/16-12UN-2B	1.622
Q - 34	2.075 (34.0)	4061 (280)	3.228	4.213	7.559	1.031	2.063	1.000	M10x1.5	1-5/16-12UN-2B	1.937
Q - 43	2.624 (43.0)	3916 (270)	3.524	4.508	7.854	2.311	1.189	1.205	M12x1.75	1-5/16-12UN-2B	1.937
Q - 51	3.112 (51.0)	3624 (250)	3.799	4.783	8.130	2.752	1.406	1.457	M12x1.75	1-5/16-12UN-2B	1.937
Q - 61	3.723 (61.0)	3334 (230)	4.134	5.118	8.465	2.752	1.406	1.457	M12x1.75	1-5/16-12UN-2B	1.937
Q - 71	4.333 (71.0)	3044 (210)	4.468	5.453	8.799	2.752	1.406	1.457	M12x1.75	1-5/16-12UN-2B	1.937
Q - 82	5.004 (82.0)	2611 (180)	4.823	5.807	9.154	2.752	1.406	1.457	M12x1.75	1-5/16-12UN-2B	1.937
Q - 100	6.102 (100.0)	2611 (180)	5.276	6.713	10.060	2.752	1.406	1.457	M12x1.75	1-5/16-12UN-2B	1.937

Caution!

- The packing foil is recyclable.
- Certified documentation is available per request.

ARGO-HYTOS a. s. CZ - 543 15 Vrchlabí
Tel.: +420-499-403111, Fax: +420-499-403421
E-mail: sales.cz@argo-hytos.com
www.argo-hytos.com