

- 2/2 way cartridge valves solenoid operated with spool direction
- Manual override
- No spool sticking by too a high tightening torque
- High transmitted power

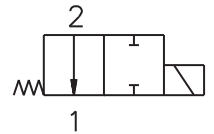

Functional Description

The directly operated 2/2 way solenoid actuated spool valve controls in the first line the start and stop function of the oil flow. The valve consists of the valve body (1), control spool (2), return spring (3), cartridge with actuating system (4) and of the solenoid coil (7) that is mounted on the actuating system. The valve bushing is screwed into the cartridge part (4).

The valve bushing is fixed in the cartridge by a wire ring (5) and sealed with the seal ring (6). Separation of the valve bushing and the cartridge prevent transmitting the stresses, which could be caused by too high tightening torques. The DC solenoid coils can be delivered for 12 V and 24 V supply voltages. For AC applications 120 V/ 60 Hz or 230 V/ 50 Hz,

the suitable rectifiers for the standard solenoid coils are available, with them being mounted in an additional terminal box. With the high power solenoid coils in AC variants, the rectifiers are integrated directly in the connector. By loosening the fixing nut (8), the solenoid coil can be replaced or turned in the range of 360°. The valve body is zinc coated.

Note:

The valves are supplied without solenoids coils. The solenoid coil, the terminal box and the housing body for line mounting have to be ordered separately.

Standard performance

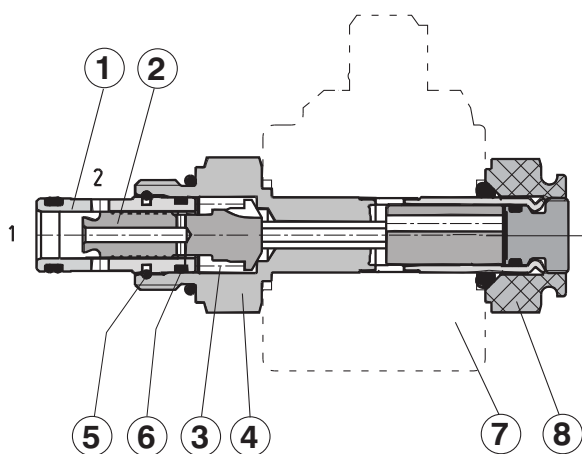

High performance

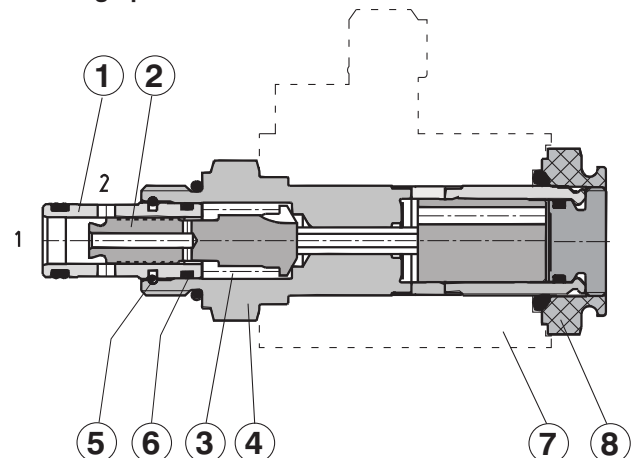

Ordering Code

SD2E-A2 /

**2/2 Way Solenoid Operated
Directional Control Valve Spool**

Standard
High performance

Description
Refer to the table with functional symbols

S
H

no designation
V

Seals
standard (NBR)
Viton (FPM)

No designation
M2
M5
M9

Manual override
standard
covered with rubber boot
socket head screw
without manual override

Solenoid coil, terminal box and body for line mounting have to be ordered separately. For selection of solenoid coil and terminal box type use catalogue HA 8007. For selection of valve body for in-line mounting use catalogue HA0018.

Functional Symbols

Designation	Symbol	Interposition	Designation	Symbol	Interposition
2111			2112		

Manual Override

Dimensions in millimeters (inches)

No designation - standard

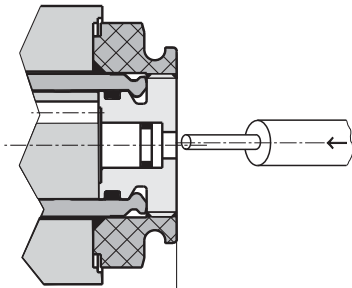

Standard valve ~64,5 (2.539)
High performance valve ~70,0 (2.756)

Designation M9 - without manual override

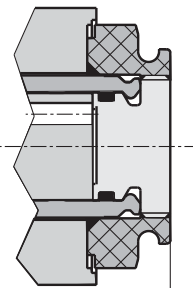

Standard valve ~64,5 (2.539)
High performance valve ~70,0 (2.756)

Designation M2 - covered with rubber boot

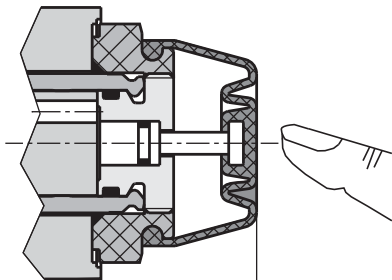

Standard valve ~75,5(2.972)
High performance valve ~81,5(3.209)

Designation M5 - with socket head screw 2.5 (0.098)

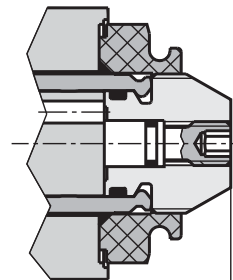

Standard valve ~71,5(2.815)
High performance valve ~77,5(3.051)

Technical Data

		Standard	High performance
Cartridge thread		3/4-16 UNF-2B	
Maximum flow	L/min (GPM)	20 (5.3)	30 (7.9)
Max. operating pressure	bar (PSI)	250 (3626)	350 (5076)
Pressure drop	bar (PSI)	see Δp -Q characteristics	
Hydraulic fluid		Hydraulic oils of power classes (HL, HLP) to DIN 51524	
Coil groups (see the datasheet of coils)		C 51-26	C 04-20
Fluid temperature range	°C (°F)	-20 ... 60 (-4 ... 140)	-20 ... 80 (-4 ... 176)
Ambient temperature, max.	°C (°F)	-20 ... 50 (-4 ... 122)	-20 ... 80 (-4 ... 176)
Viscosity range	mm ² /s (SUS)	10 ... 500 (49 ... 2450)	
Maximum degree of fluid contamination		Class 21/18/15 according to ISO 4406 (1999)	
Permissible rated voltage variation	%	AC,DC ±10	AC,DC ±15
Max. switching frequency	1/h	15 000	
Duty cycle	%	100	
Enclosure type to EN 60529		IP 65	
Service life	cycles	10 ⁷	
Maximum valve tightening torque	Nm (lbf.ft)	30+2 (22.127+1.475)	
Maximum plastic nut tightening torque	Nm (lbf.ft)	3+1 (2.213+0.738)	5+1 (3.688+0.738)
Weight	kg(lbs)	0,10 (0.22)	0,20 (0.44)
Mounting position		optional	

p-Q Characteristics

Measured at $v = 32 \text{ mm}^2/\text{s}$ (156 SUS)

Operating limits for hydraulic power transferred by the directional valve. For respective spool type - see functional symbols.

Standard valve

Oil 60 °C(140 °F) / Ambient temperature 40 °C (104 °F)
Voltage Un [V]

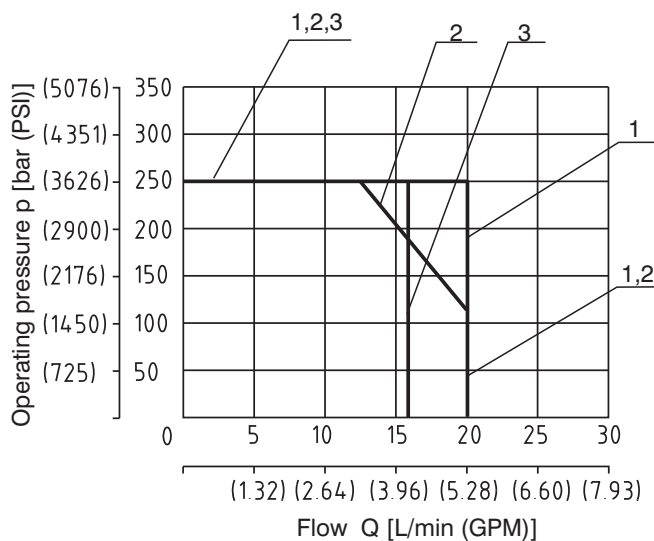

	Connection	Direction
1	2111	2→1
1	2112	1→2
2	2111	1→2
3	2112	2→1

High performance valve

Oil 80 °C (176 °F) / Ambient temperature 50 °C (122 °F)
Voltage Un -10% [V]

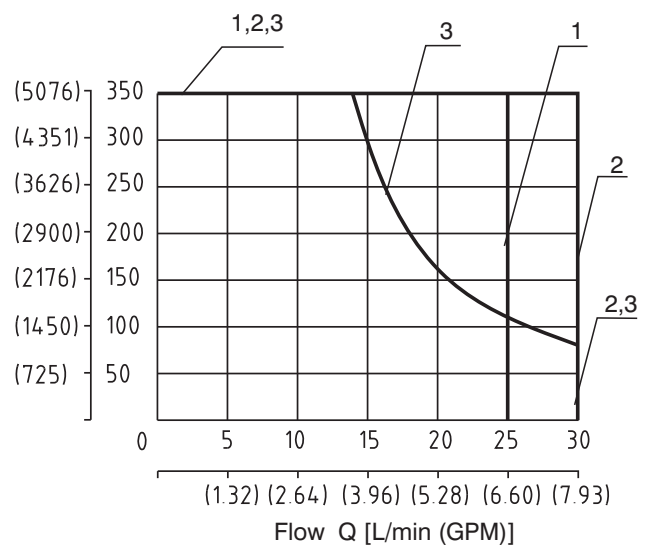

	Connection	Direction
1	2112	2→1
2	2112	1→2
2	2111	2→1
3	2111	1→2

Δp-Q Characteristics

Measured at $v = 32 \text{ mm}^2/\text{s}$ (156 SUS)

Pressure drops related to flow rate.

Standard valve + High performance valve

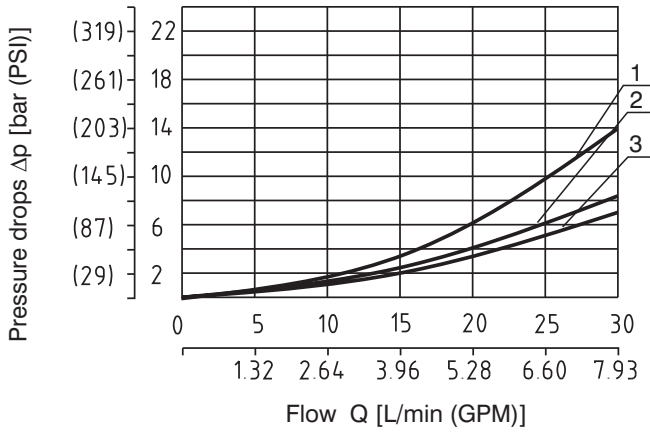

	Connection	Direction
1	2112	1→2
1	2112	2→1
2	2111	1→2
3	2111	2→1

Type of the Solenoid Coils

Dimensions in millimeters (inches)

**Coil for Standard valve
C51-26**

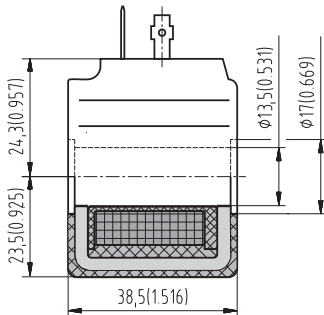

**Coil for High performance valve
C04-20**

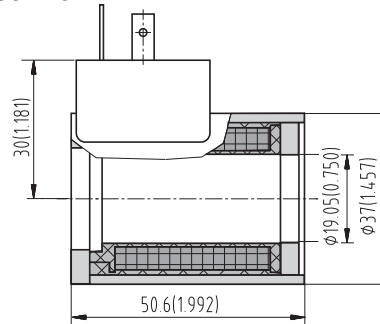

Note:

Example of most frequent coil types.

For complete range of SD2E-A2 valve coils with technical informatik about voltage, terminal box please afer to coil data sheet HA 8007.

Solenoid	Connector	Standard valve	High performance valve
		SD2E-A2 / S...	SD2E-A2 / H...
		Type code	Type code
12 VDC	EN 175301-803 with quenching diode	C51-26-012DC-E2	C04-20-012DC-E2
24 VDC	EN 175301-803 with quenching diode	C51-26-024DC-E2	C04-20-024DC-E2
12 VDC	AMP-Junior-Timer (with quenching diode)	C51-26-012DC-E4	C04-20-012DC-E4
24 VDC	AMP-Junior-Timer (with quenching diode)	C51-26-024DC-E4	C04-20-024DC-E4
120 VAC	EN 175301-803 with rectifier	-	C04-20-120AC-E5
230 VAC	EN 175301-803 with rectifier	-	C04-20-230AC-E5
120 VAC	EN 175301-803	C51-26-105DC-E1*	C04-20-105DC-E1*
230 VAC	EN 175301-803	C51-26-205DC-E1*	C04-20-205DC-E1*

*Use the terminal box with rectifier!

Valve Body

Dimensions in millimeters (inches)

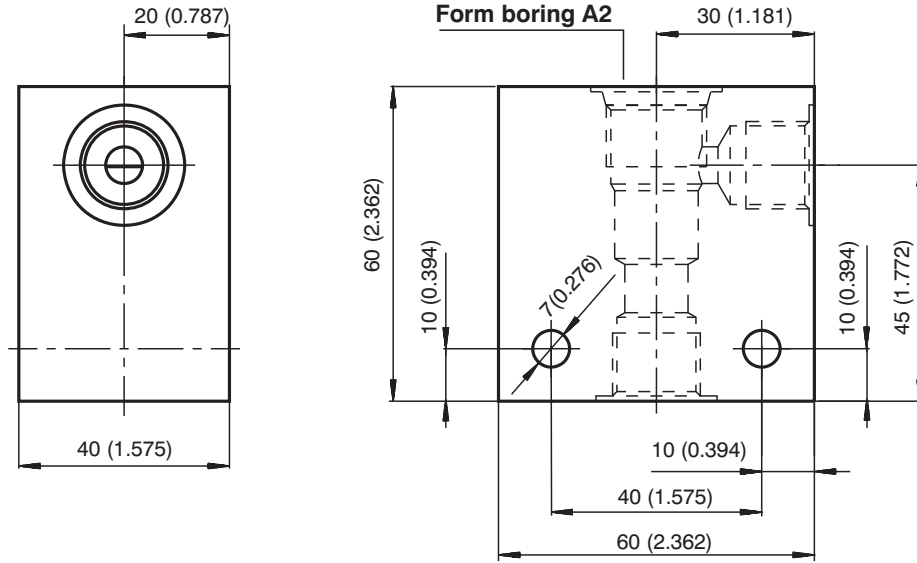

Body material	Connecting size	Type code	Operating pressures
Steel	G3/8	SB-A2-0103ST	420 bar (6091 PSI)
Steel	SAE 6	SB-A2-0102ST	420 bar (6091 PSI)
Aluminium	G3/8	SB-A2-0103AL	250 bar (3626 PSI)
Aluminium	SAE 6	SB-A2-0102AL	250 bar (3626 PSI)

Note:

- For detailed valve body ordering code refer to data sheet HA 0018

Valve Dimensions

Dimensions in millimeters (inches)

Standard valve

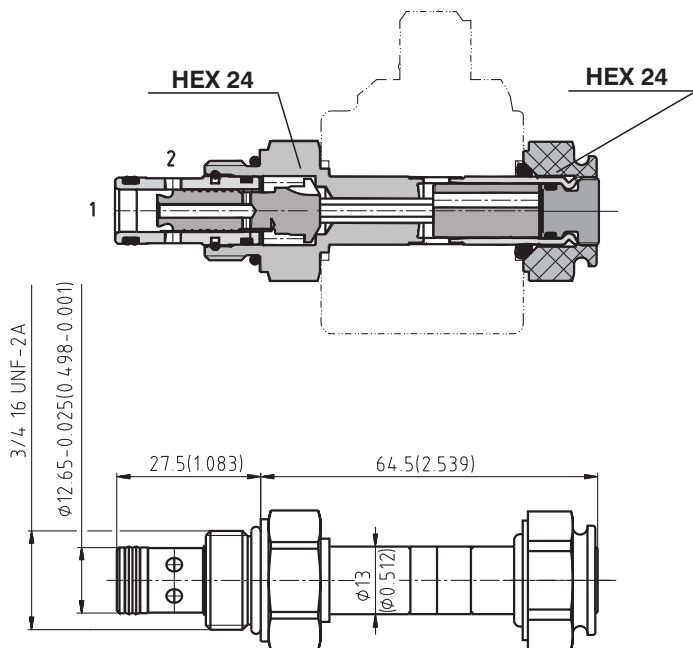

High performance valve

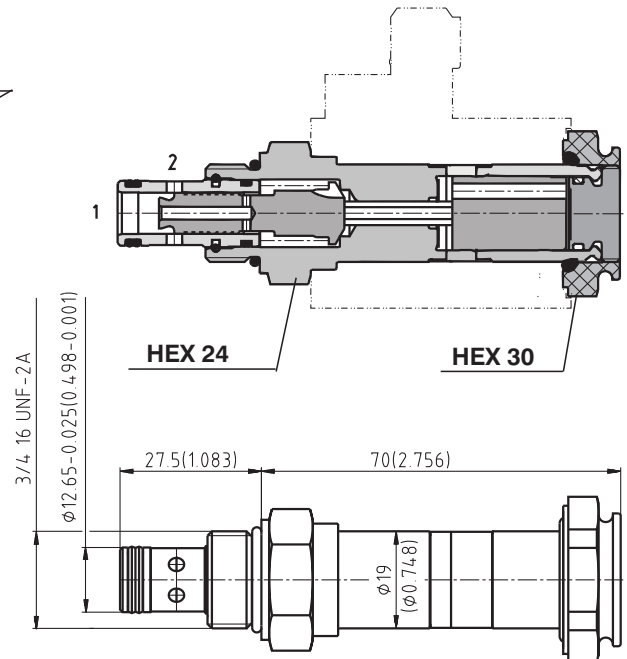

Cavity

Dimensions in millimeters (inches)

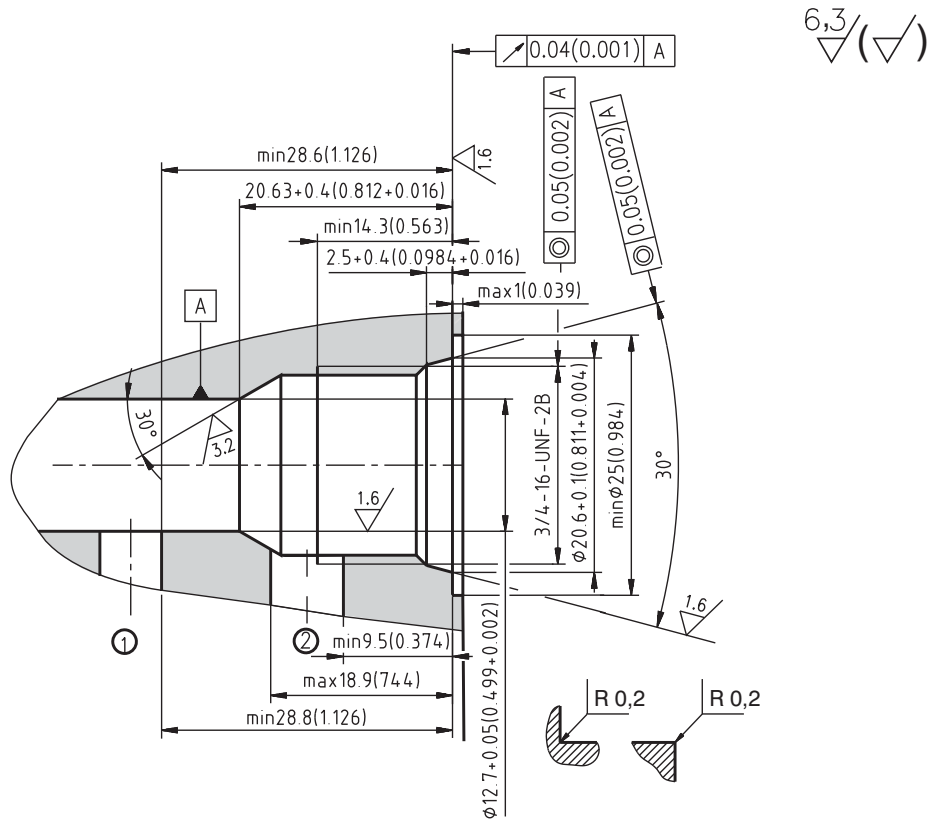
**Spare Parts**

Dimensions in millimeters

Standard and high performance valve

Dualseal - PU	O-ring - NBR	O-ring - Viton	Order number
10,3 x 12,7 x 3,1 (1pc.)	17 x 1,8 (1pc.)	-	408-9001
10,3 x 12,7 x 3,1 (1pc.)	-	17,17 x 1,78 (1pc.)	408-9002

Solenoid retaining nut with seal for standard valve

Type of nut	O-ring - Viton	
Standard nut	12,3 x 2,4 (1pc.)	408-9003
Nut M2	12,3 x 2,4 (1pc.)	408-9010

Solenoid retaining nut with seal for high performance valve

Type of nut	O-ring - Viton	
Standard nut	20 x 2,5 (1pc.)	408-9004
Nut M2	20 x 2,5 (1pc.)	408-9011

Caution!

- The packing foil is recyclable.
- The technical information regarding the product presented in this catalogue is for descriptive purposes only. It should not be construed in any case as a guaranteed representation of the product properties in the sense of the law.

ARGO-HYTOS s.r.o. CZ - 543 15 Vrchlaví
 Tel.: +420-499-403111, Fax: +420-499-403421
 E-mail: sales.cz@argo-hytos.com
 www.argo-hytos.com